

Aqua-Aire®
Standard Cascade™ with
Built in Swivel Lift Bathing System
Installation / Assembly Instructions Manual



PENNER PATIENT CARE, INC
Box 523 / 102 Grant St.
Aurora, NE 68818

360745WT Revision A – 08/11/09

1-866-PENNERS

1-866-736-6377

1-800-732-0717

TUB MODELS 360010-1WT, 360010-XWT, 360010-1WTL, 360010-XWTL
RESERVOIRS- 370000-1W, 370000-1WL, 370000-XW, 370000-XWL

E-mail Address: pennersales@hamilton.net
Web Site: www.pennerpatientcare.com

Table of Contents

TABLE OF CONTENTS	2
INTRODUCTION:	3
TERMINOLOGY AND SYMBOLS MEANINGS:.....	3
BASIC ROOM DIMENSIONS:	3
DRAIN REQUIREMENTS:	6
HOT AND COLD WATER SUPPLY REQUIREMENTS:.....	5
ELECTRICAL REQUIREMENTS:.....	5
UNPACKING THE TUB:.....	6
UNPACKING THE RESERVOIR:	6
TUB MODIFICATIONS FOR RESERVOIR:	6
ASSEMBLING THE RESERVOIR:	7
WATER SUPPLY HOSE CONNECTIONS:.....	7
ANCHORING THE TUB/RESERVOIR:	7
WATER SUPPLY AND DRAIN CONNECTIONS:.....	8
ELECTRICAL CONNECTIONS:	8
FINISHING UP:.....	9
TUB AND RESERVOIR CONTROLS:	10

Plumbing Requirements:

It is required that a licensed plumber make all plumbing connections. He can select the best method of connection and if Reduced Pressure Zone Backflow Preventers are required.

Introduction:

These instructions are for the installation of the Cascade™ Tub with Swivel Lift System, with or without a Cascade™ Reservoir. The **Reservoir is an optional accessory**, which is to be pre-filled prior to placing the resident into the tub. Then the water in the reservoir can be released into the tub. This shortens the time required before the tub is full and the bathing can be started.

Terminology and Symbols Meanings:

When the terms “left” or “right” are used with reference to the tub, this means left or right as you look at the control panel from the seat end of the tub.



Meaning: **Safety warning. Failure to understand and obey this warning may result in injury to you or to others.**

CAUTION

Meaning: **Failure to follow these instructions may cause damage to parts or systems.**

Note: Refer to the “Tub Controls” section of this manual for the location of any of the controls referenced.

Basic Room Dimensions:

Figure 1 shows a room layout for a Standard Cascade™ Tub / Swivel Lift System with a reservoir.

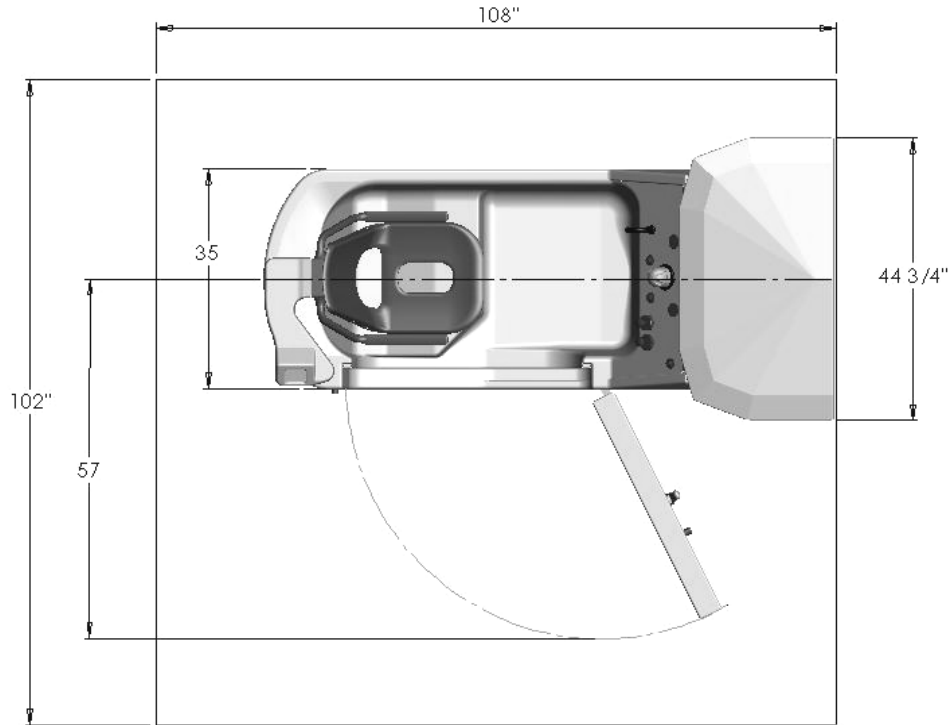

Figure 1
Room layout for Standard Cascade™ Swivel Lift System with Reservoir

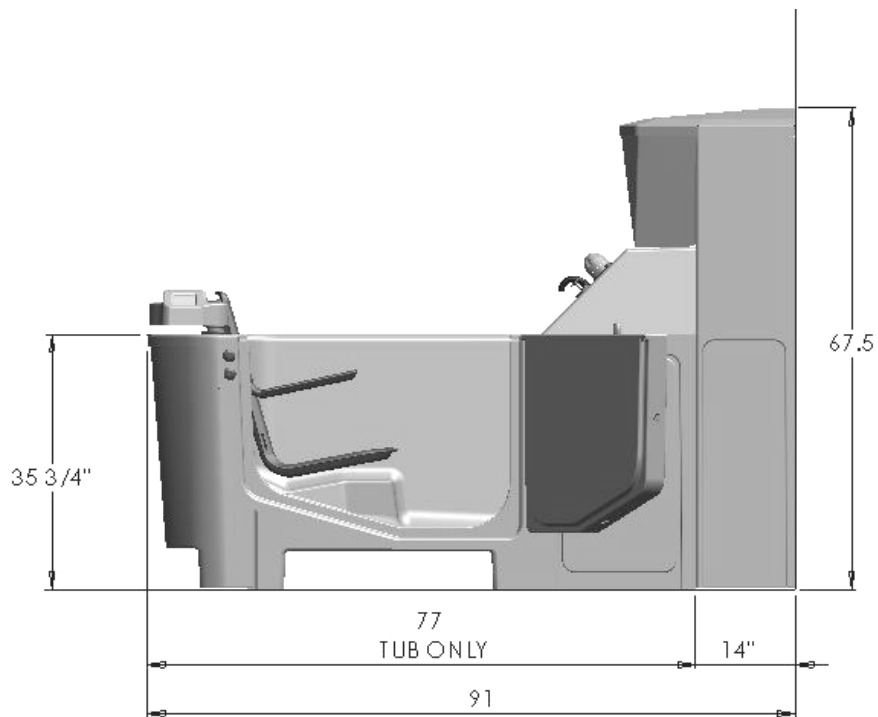

Figure 2
Side View of Standard Cascade™ Swivel Lift Tub
With and without Reservoir

Drain requirements:

Figure 3 shows two different options for roughing in the drain pipe – from the floor or from the wall. The tub is equipped with a 2” nominal (2 3/8” O.D.) PVC drain pipe. As shown in Figure 3. The tub’s drain pipe is approximately 11” from the wall and 5 1/4” above the floor, and 20” from the wall with a reservoir. It is required that a licensed plumber make all plumbing connections. He can select the best method of connection for the particular situation and if Reduced Pressure Zone Backflow Preventers are required.

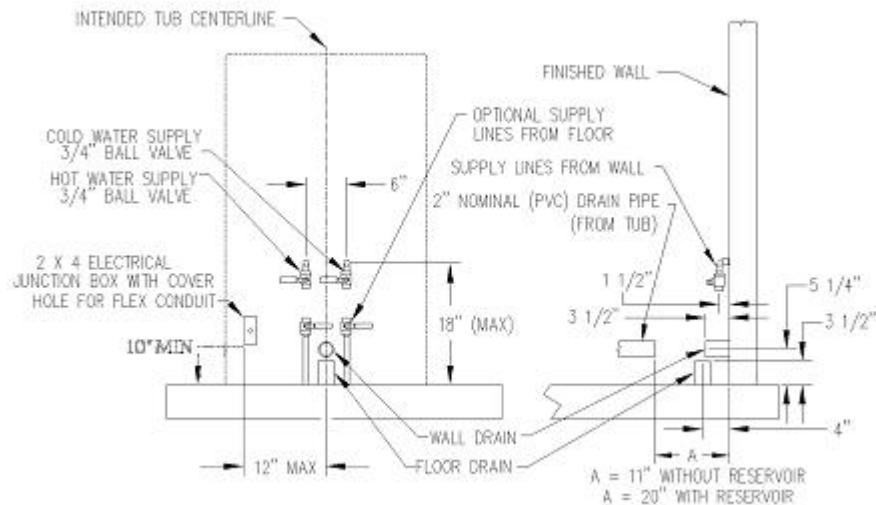

Figure 3
Suggested Rough-ins

Hot and cold water supply requirements:

3/4” supply lines with on/off valves with 3/4” NPT female threads. We recommend 3/4” ball valve with 3/4” NPT female ports. (Valves supplied by others.) See **Figure 3** for recommended locations.

For optimum performance, dynamic pressures should be nominally equal between hot and cold supplies.

Maximum static supply pressure: 145 PSI.

Maximum dynamic/maintained supply pressure: 81 PSI.

Maximum supply Hot water temperature: Consult local requirements for maximum allowed supply temperatures. (Not recommended over 120°F)

Electrical requirements:

The Cascade™ Tub Aqua-Air® (with reservoir) is rated 9.5 amps at 120 Volts AC. A 20 amp GFCI circuit is required.

(The optional Cascade™ Reservoir, is rated at .75 amp and is connected to the tub’s electrical box via hard wiring.)

Unpacking the tub:

1. Remove the tub from the shipping crate.
2. Locate and save the installation parts.
3. Remove all access doors and place them where they will not be damaged during the installation process.
4. If a Cascade™ Reservoir is to be installed with the tub, continue with “Unpacking the Reservoir.” If not, skip to “Water Supply Hose Connections.”

Unpacking the Reservoir:

1. Remove the Reservoir from the shipping crate.
2. Locate and save the installation parts.
3. Remove all access doors and place them where they will not be damaged during the installation process.

Tub Modifications for Reservoir:

Cascade™ Tubs are manufactured and packed for installation without a reservoir. To install it with a reservoir, a couple of modifications are required.

1. The “wall trim” on the end of the tub is for installing against a wall. This wall trim can be removed and replaced with either the “blue” or “off white” trim, or not use it at all. These trims are supplied with the reservoir.
2. Remove the black hole plug located just above the overflow escutcheon by removing the plastic nut. This plug and nut can be discarded
3. Replace the plug with the reservoir outlet fitting, Gasket, and outlet adapter. (These are packed with the reservoir) See **Figure 4** for assembly order. Ensure that the opening of the outlet fitting is pointed directly down after final tightening.
4. Unscrew and remove the cap from the water line port that points out the back of the tub. This will be the connecting point for the reservoir supply hose.

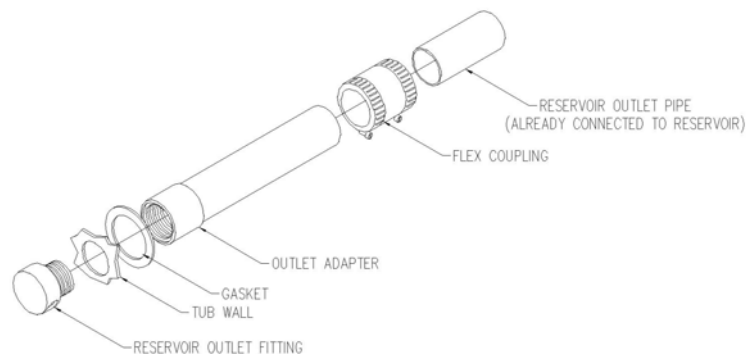

Figure 4
Reservoir Outlet Assembly

Assembling the Reservoir:

1. Locate the Reservoir at the back end of the Cascade™ Tub and use the provided hardware (3/8 x 3 3/4" bolts, flat washers, and hex nuts) to affix the reservoir to the frame of the tub's frame through the holes provided. Ensure that the reservoir is centered with the tub. Snug up the hex nuts, but do not over-tighten the nuts.
2. Connect the reservoir outlet pipe to the outlet adapter with the provided flex coupling and tighten. Reference **Figure 4**.
3. Connect the reservoir supply hose, from the reservoir plumbing assembly, to the water line port at the back of the tub.
4. Connect the overflow tee to the drain of the tub.

Water Supply Hose Connections:

1. Locate one of the provided connecting hoses (packed with the tub) and connect the male thread end to the hot water supply ball valve.
2. Connect the male threaded end of the other provided connecting hose to the cold water supply ball valve.

Anchoring the Tub/Reservoir:

1. Anchoring the tub to the floor **is required** on the built in Swivel Lift tub.



Warning: The Built in Swivel Lift Tub must be anchored to the floor. Failure to anchor the Built in Swivel Lift Tub to the floor could result in injury to the operator or resident.

Note:

These instructions for anchoring the tub are written with the assumption that the installation is being done on a concrete floor. If this is not the case, consult an Architect. There are three anchoring locations, two at the control end, and one at the seat end of the tub (see **Figure 5**). Anchoring the Reservoir is not necessary.

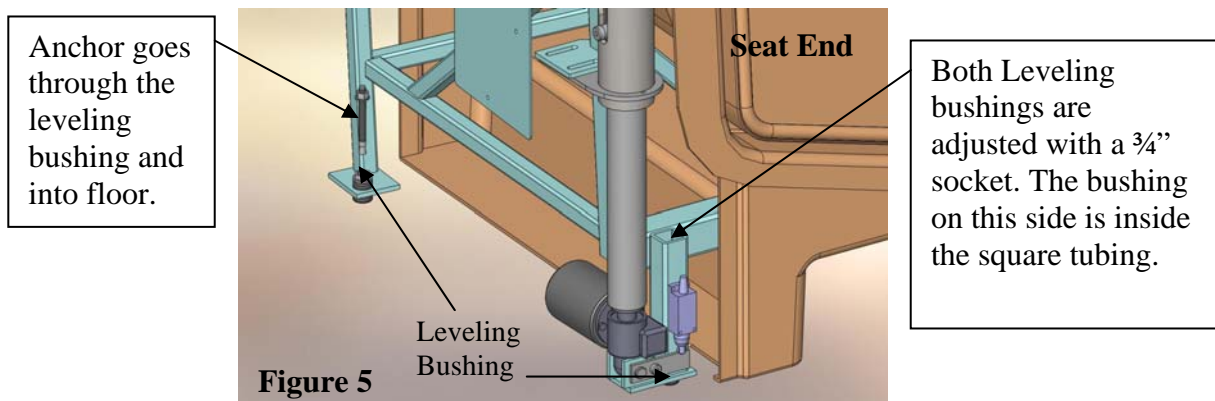

2. Remove the end panel, at the seat end of the tub, and set it to the side.
3. The tub is heavy and is not easy to move. Picking up on the tub as it is pushed helps. With the help of 2 or 3 additional people, place the tub/reservoir in the final installation position. The reservoir, if used, should be against the wall.

4. The leveling bushings are to be adjusted and can be done with a 3/4" socket as shown in **Figure 5**.
5. Using a 5/16" masonry bit, drill one anchor hole on each side of the tub, just inside the large access doors at the control end of the tub. They need to be drilled through the fiberglass return flange and on into the concrete floor. (1 1/2" deep)
6. Using a 3/8" masonry bit, drill through the one leveling bushing into the concrete floor as shown in **Figure 5**. (2" deep)
7. Clean the drilled holes and clean the drilling dust from the area.
8. Insert the provided 3/8" anchor through the leveling bushing and into the anchor hole just drilled.
9. Insert the two provided 5/16" anchors into the holes just drilled into the return flanges at the control end of the tub.
10. Tighten the anchor nuts.
11. Re-install the end panel on the tub.

Water Supply and Drain Connections:

Note: It is required that a licensed plumber make the connections of the hot and cold water supply and the connection to the drain and if Reduced Pressure Zone Backflow Preventers are required.

1. Connect the ends of the connecting hoses (hot and cold water supply) to the respective ports on the tub. Ensure that there are sealing gaskets within the swivel fittings on the hoses.
2. Connect the drain (waste) of the tub to the facility's drain system.
3. The system needs to be checked for any leaks in the entire system. However, the electrical connections must be made prior to doing this. Once the electrical connections have been made, continue with step 4.
4. Open the facility's supply valves to the tub and check for leaks. If no leaks are found, check the entire plumbing system for any leaks. Look for leaks while each of the following systems are running: "Tub fill", "Shower", and "Disinfecting" per the provided Cascade™ Tub with Swivel Lift Operation Manual .

Electrical Connections:



Warning:

This unit is to be connected only by a licensed electrician. A minimum of 20 amp 120 volt service is required with ground fault circuit interrupter. Before installation turn off the power at circuit breaker. Lock circuit open to prevent accidental activation.

1. Remove the covers from the electrical box of the tub (and reservoir).
2. For tubs with reservoirs, connect the reservoir electrical supply lead to the tub's electrical kit.
 - a. Remove the hole-plug from the left side of the tub electrical box.

- b. Run the cable lead through that hole and secure using the cord restraint and nut provided.
 - c. Connect the line wire to the line distribution bar located in the upper right corner of the tub's electrical box. It will have only black wires connected to it. See **Figure 6**.
 - d. Then connect the neutral and ground wires, neutral, and ground terminals respectively. These are labeled accordingly.
 - e. Replace the cover of the reservoir's electrical box.
3. Run flexible conduit and the proper size wires, from the facility's junction box to the connecting point of the tub's electrical enclosure. (Located inside the large access door opening on the "left" side of the tub.)
 4. Connect the ground to the "protective earth" (ground) bar.
 5. Connect the neutral wire to neutral bar marked "N".
 6. Use the provided female disconnect wire terminal to connect the "line" wire to the circuit breaker tab marked "L". The provided female disconnect wire terminal is shipped already connected to the circuit breaker.
 7. Replace the electrical enclosure cover. With the tubs circuit breaker switch in the "OFF" position, turn "ON" the circuit to the tub.
 8. Switch the tub's circuit breaker to the "ON" position. The temperature gauges should now display a temperature reading.

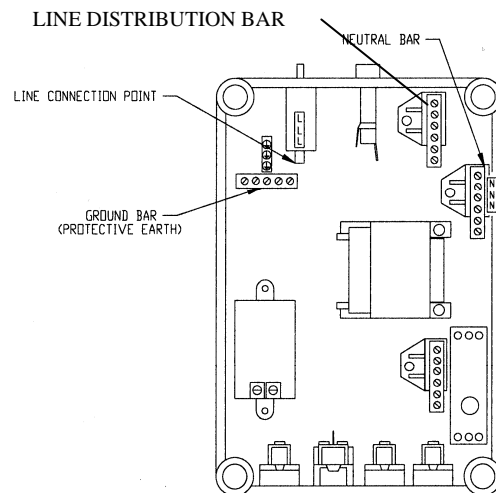

Figure 6
Tub Electrical Box

Finishing up:

1. Once the tub/reservoir has been connected to the drain, checked for leaks (and fixed if needed), and is connected to power, the access doors can be installed.
2. Train all operators of this equipment before using it per the Safe Operation & Daily Maintenance Instruction Manual.



Warning!

Because this equipment requires a trained operator, and to assure that these benefits are realized, **do not operate** your PMI equipment until an authorized member of your staff has reviewed the Safe Operation & Daily Maintenance Instruction Manual and spoken to your PMI Representative. Failure acquire this training could result in damage to the equipment or injury to the operator and resident. If needed, Your PMI Products Representative will assist you with questions you may have in the operation of this equipment.

Tub and Reservoir Controls:

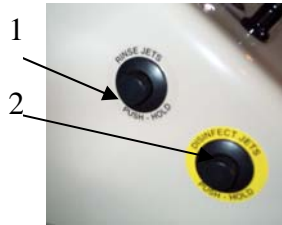
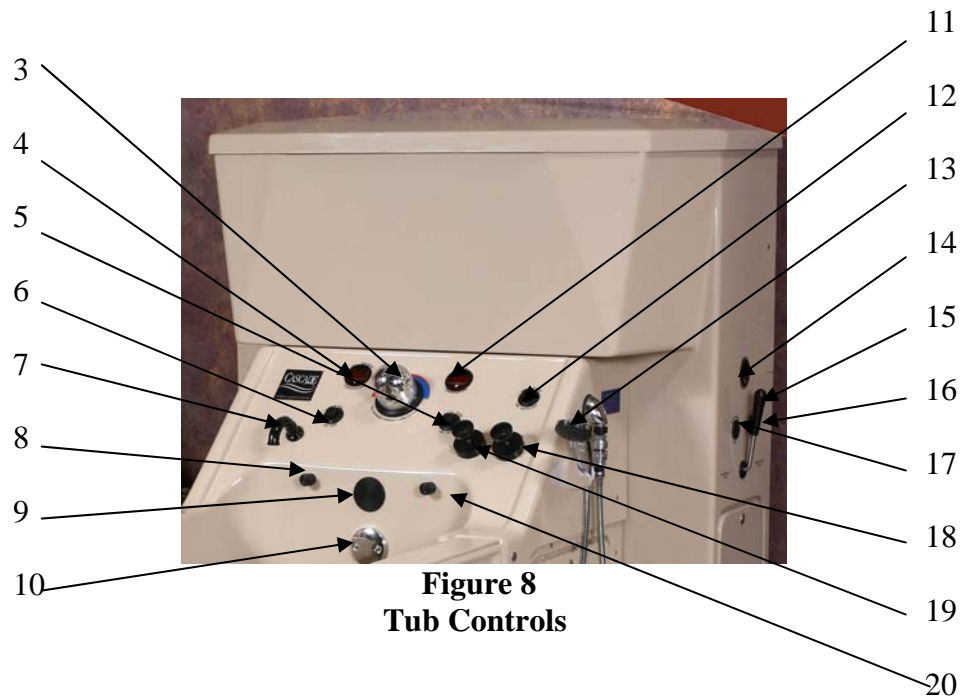

Figure 7



**Figure 8
Tub Controls**

- 1 Rinse button (Aqua-Air® tubs only)
- 2 Disinfect button (located on the left side of the tub)
- 3 Mixing valve – Temperature control
- 4 Fill / Shower water temperature readout
- 5 Whirlpool or Aqua-Air® ON/OFF button
- 6 Tub fill ON/OFF button
- 7 Filling spout
- 8 Bath oil dispensing spout
- 9 Reservoir outlet *
- 10 Drain plug cable
- 11 Tub water temperature readout
- 12 Shower ON button (The unit has a time adjustable automatic shut-off)
- 13 Hand shower sprayer
- 14 Reservoir Temperature readout *
- 15 Reservoir fill lever*
- 16 Reservoir fill off button (not showing)*
- 17 Reservoir fill on button*
- 18 Shampoo dispensing pump plunger
- 19 Bath oil dispensing pump plunger
- 20 Shampoo dispensing spout

* On Reservoir equipped units only.

For your nearest distributor, contact:

***PENNER PATIENT CARE, INC.
Box 523 / 102 Grant St.
Aurora, NE 68818***

1-866-PENNERS

1-866-736-6377

1-800-732-0717

***E-mail Address: pennersales@hamilton.net
Web Site: www.pennerpatientcare.com***